



Sliding Gate CT806

All the gates models are space efficient security barriers, with a compact design, yet offer sufficient space to integrate any access control system. They can be mounted with display, passage counter, card reader, token operation traffic lights, command console, alarm system against unauthorized entries, interfaced with a PC through a RS232(RS485,TCP-IP)line. The unique swing arm feature provides a fail-safe safety solution in case of an emergency or power failure, providing egress in case of crisis evacuations. Durability with minimal maintenance means years and millions of trouble free passages. The gate creates a secure environment in. for example, a reception area. Our gates are used in applications including stadiums and arenas, perimeter and interior security, recreation and amusement parks, retail crowd control, transit fare collection and lobby access control.

OPERATING MODES

- Single passage in the set direction
- Bi-directional single passage
- Free passage in the set direction
- Always free or locked

MATERIALS

- Housing: Made in stainless steel AISI 304 o AISI316
- Barrier swings-Acrylic, PC , stainless steel frame

FEATURES AND BENEFITS

- Use IC cards, ID cards, Bar code or magnetic cards as automatic identification system and achieve access, attendance fees or function
- A direction indicator, showed that pedestrian access to the current status of, and guide pedestrians correct and smooth passage
- Display has been in use for statistics and numbers
- With voice and strobe light alerts
- A combination of infrared sensors and police ant illegal entry into pedestrian access, the protection of pedestrians smooth and the prevention of the channel following
- Double anti-clipping function, photocell antic lipping and mechanical anti-clipping
- Auto re-set function, if no passing during identified card-reading time, the system will reset automatically the passengers are prohibited to pass until their second identified reading
- The barrier can be set to delay closing in 1-60s after a valid card-reading

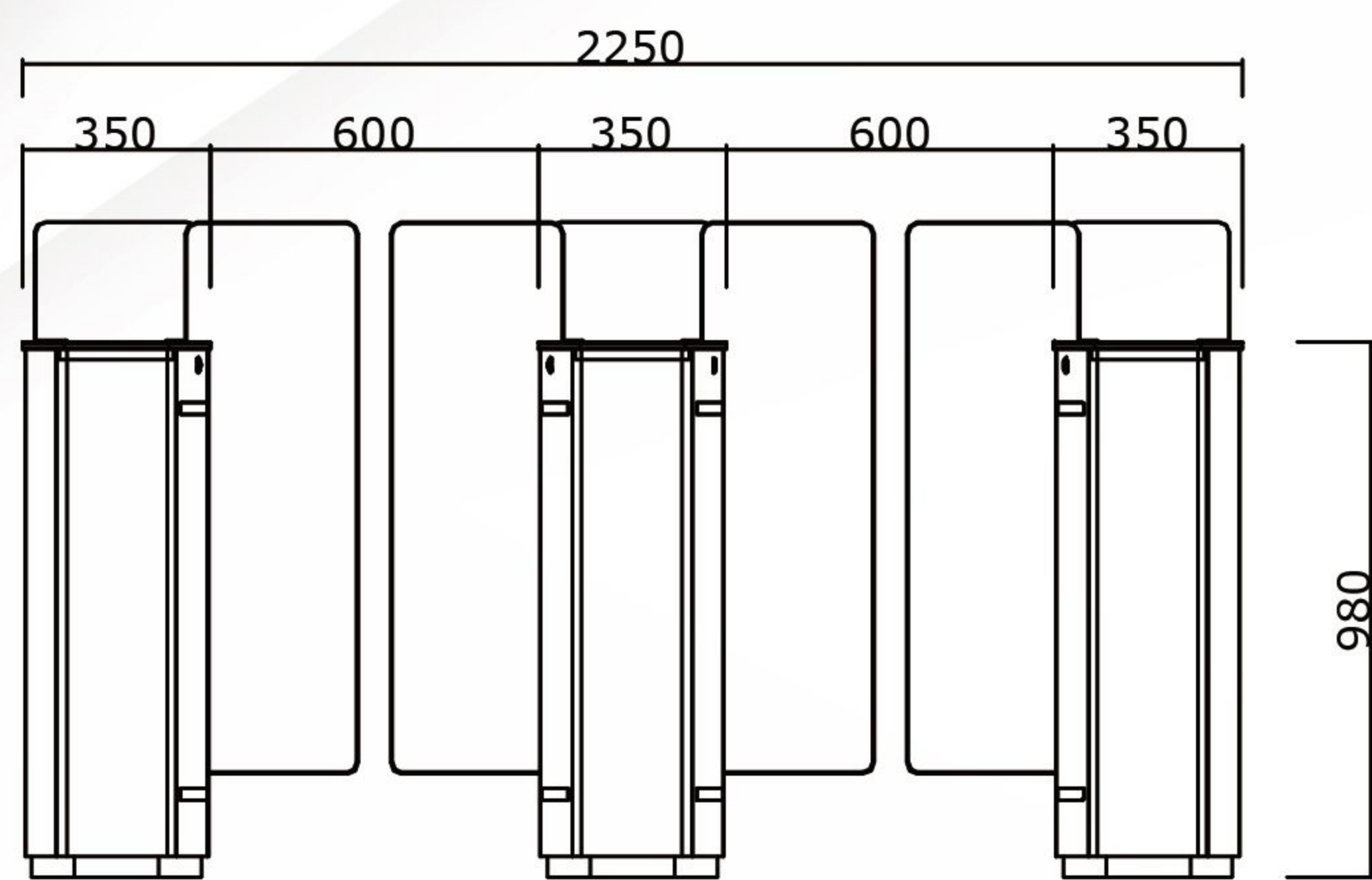
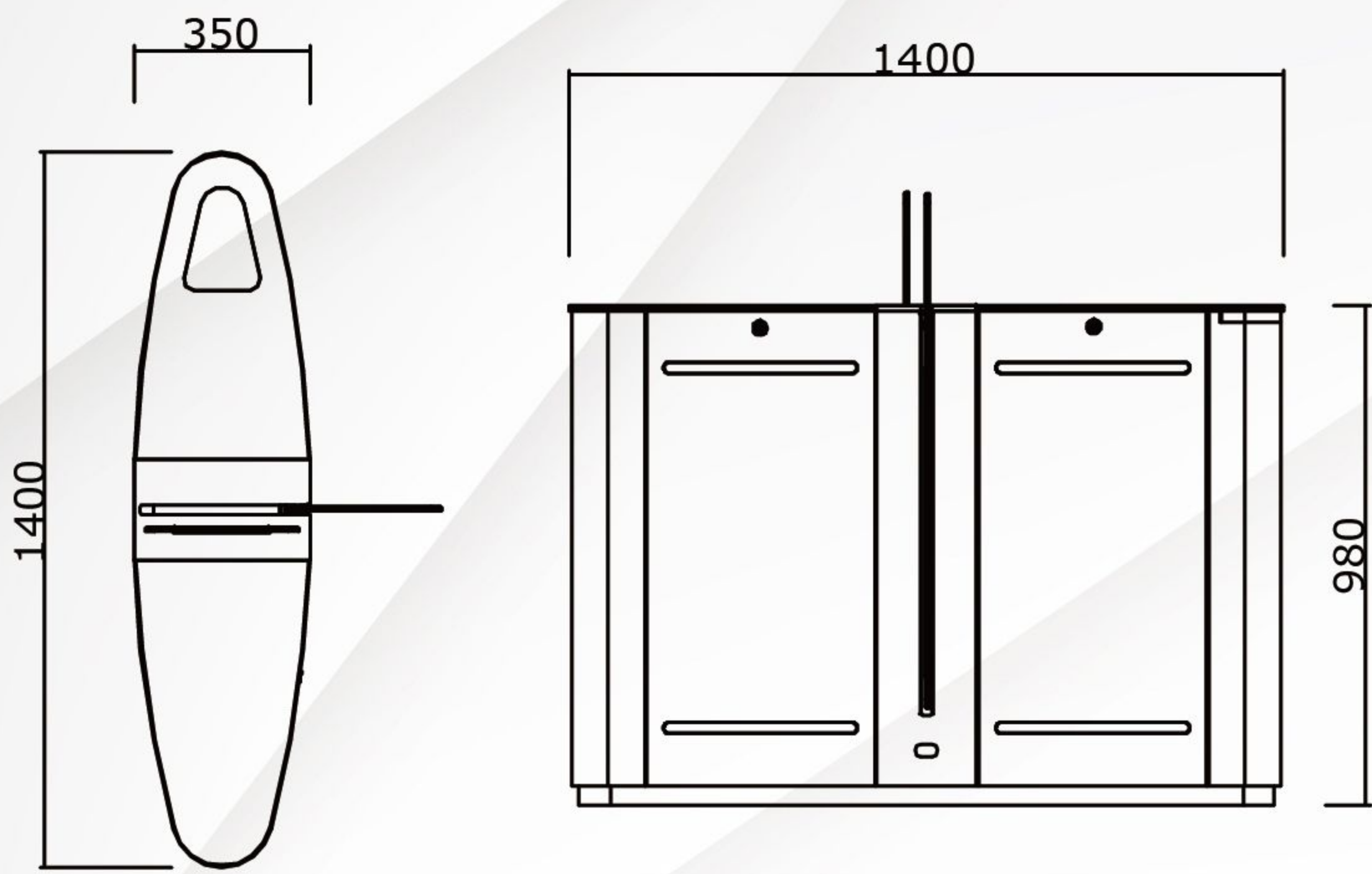

| Technical Data | Unit | |
|---------------------------|--------|--------------|
| Passage width | mm | ≤600 |
| Throughput rate | p/m | 35 |
| Power supply | V/(ac) | 100-240 |
| Operational voltage | V/(dc) | 24 |
| Max power consumption | w | 35 |
| Frequency | hz | 50-60 |
| Protection level | IP | >44 |
| Working temperature | degree | -25 to +70 |
| Dimension excluding bars | mm | 1400*350*980 |
| Net weight including bars | Kg | 95 |

Project Cases

